

MPEG Clock Generator with VCXO

Features

- Integrated phase-locked loop (PLL)
- Low-jitter, high-accuracy outputs
- VCXO with analog adjust
- 3.3V operation
- Compatible with MK3727 (-1, -5)

Benefits

- Highest-performance PLL tailored for multimedia applications
- Meets critical timing requirements in complex system designs
- Large ± 150 -ppm range, better linearity
- Application compatibility for a wide variety of designs
- Enables design compatibility
- Advanced Features
 - Matches nonlinear MK3727A VCXO control curve (-5)
 - Digital VCXO control
- Electromagnetic interference (EMI) reduction for standards compliance
- Second source for existing designs

Part Number	Outputs	Input Frequency Range	Output Frequencies	VCXO Control Curve	Other Features
CY2410-1	1	13.5-MHz pullable crystal input per Cypress specification	1 copy of 27 MHz	linear	Compatible with MK3727
CY2410-5	1	13.5-MHz pullable crystal input per Cypress specification	1 copy of 27 MHz	nonlinear	Matches MK3727A nonlinear VCXO Control Curve

CY2410-1, -5 Logic Block Diagram

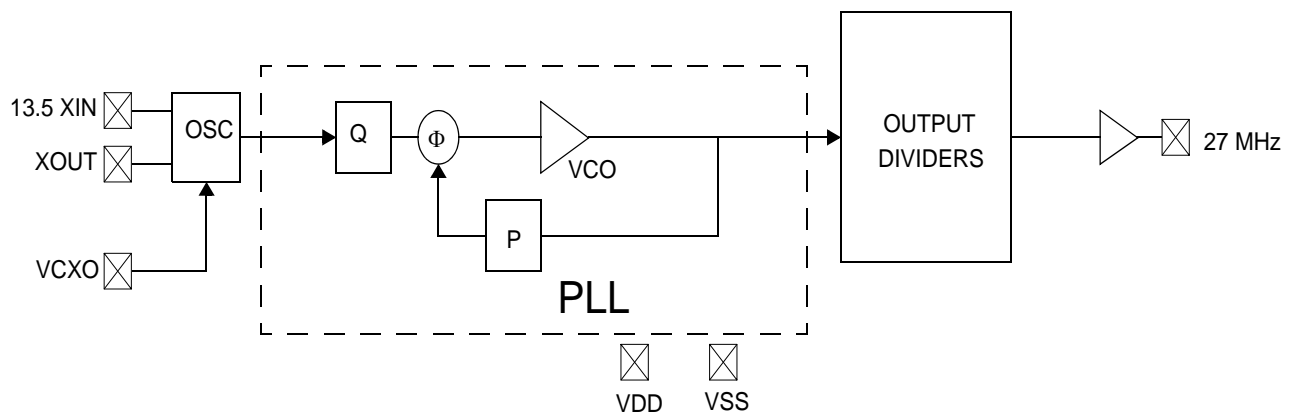

CY2410-3 Logic Block Diagram

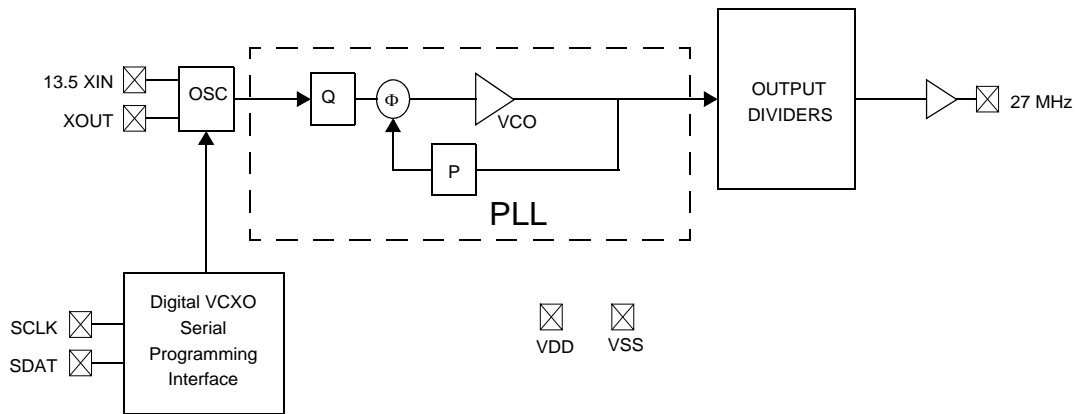

Pin Configuration

Figure 1. CY2410-1, CY2401-5 8-Pin SOIC

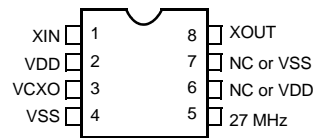

Table 1. Pin Definitions for CY2410-1, -5

Name	Pin Number	Description
X _{IN}	1	Reference crystal input
V _{DD}	2	Voltage supply
V _{CXO}	3	Input analog control for V _{CXO}
V _{SS}	4	Ground
27 MHz	5	27-MHz clock output
NC/V _{DD}	6	No Connect or voltage supply
NC/V _{SS}	7	No Connect or ground
X _{OUT} ^[1]	8	Reference crystal output

Note

1. Float X_{OUT} if X_{IN} is externally driven.

Pullable Crystal Specifications ^[2]

Parameter	Description	Condition	Min	Typ.	Max	Unit
F_{NOM}	Nominal crystal frequency	Parallel resonance, fundamental mode, AT cut	–	13.5	–	MHz
C_{LNOM}	Nominal load capacitance		–	14	–	pF
R_1	Equivalent series resistance (ESR)	Fundamental mode	–	–	25	Ω
R_3/R_1	Ratio of third overtone mode ESR to fundamental mode ESR	Ratio used because typical R_1 values are much less than the maximum spec.	3	–	–	
DL	Crystal drive level	No external series resistor assumed	–	0.5	2.0	mW
F_{3SEPHI}	Third overtone separation from $3 \cdot F_{NOM}$	High side	300	–	–	ppm
F_{3SEPLO}	Third overtone separation from $3 \cdot F_{NOM}$	Low side	–	–	–150	ppm
C_0	Crystal shunt capacitance		–	–	7	pF
C_0/C_1	Ratio of shunt to motional capacitance		180	–	250	
C_1	Crystal motional capacitance		14.4	18	21.6	pF

Note

2. Crystals that meet this specification includes: Ecliptek ECX-5788-13.500M, Siward XTL001050A-13.5-14-400, Raltron A-13.500-14-CL, PDI HA13500XFSA14XC.

Figure 2. Data Valid and Data Transition Periods

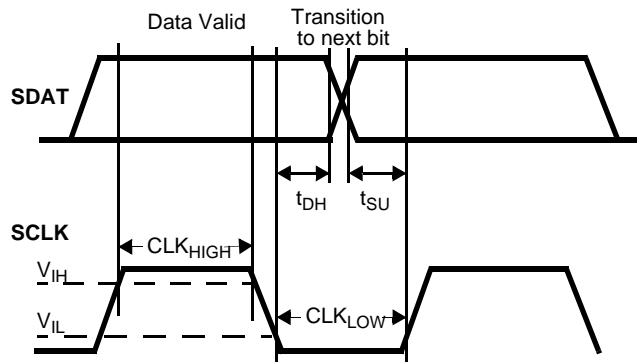

Figure 3. Start and Stop Frame

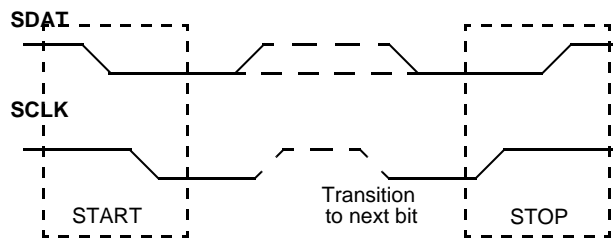

Figure 4. Duty Cycle Definition; $DC = t2/t1$

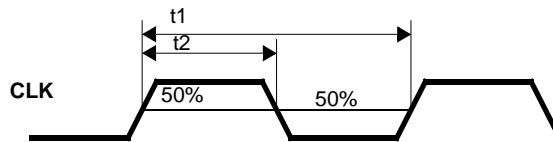
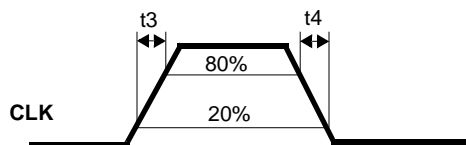

Figure 5. Rise and Fall Time Definitions: $ER = 0.6 \times VDD / t3$, $EF = 0.6 \times VDD / t4$



Absolute Maximum Conditions

Parameter	Description	Min	Max	Unit
V_{DD}	Supply Voltage	-0.5	7.0	V
T_S	Storage Temperature ^[3]	-65	125	°C
T_J	Junction Temperature	-	125	°C
	Digital Inputs	$V_{SS} - 0.3$	$V_{DD} + 0.3$	V
	Digital Outputs referred to V_{DD}	$V_{SS} - 0.3$	$V_{DD} + 0.3$	V
	Electrostatic Discharge	2000		V

Recommended Operating Conditions

Parameter	Description	Min	Typ.	Max	Unit
V_{DD}	Operating Voltage	3.135	3.3	3.465	V
T_A	Ambient Temperature	0	-	70	°C
C_{LOAD}	Max. Load Capacitance	-	-	15	pF
f_{REF}	Reference Frequency	-	13.5	-	MHz
t_{PU}	Power up time for V_{DD} to reach minimum specified voltage (power ramp must be monotonic)	0.05	-	500	ms

DC Electrical Specifications

Parameter	Name	Description	Min	Typ.	Max	Unit
I_{OH}	Output HIGH Current -1,-5	$V_{OH} = V_{DD} - 0.5, V_{DD} = 3.3V$	12	24	-	mA
I_{OL}	Output LOW Current -1,-5	$V_{OL} = 0.5, V_{DD} = 3.3V$	12	24	-	mA
C_{IN}	Input Capacitance		-	-	7	pF
I_{IZ}	Input Leakage Current		-	5	-	μA
$f_{\Delta XO}$	V_{CXO} pullability range:-1,-5		±150	-	-	ppm
V_{VCXO}	V_{CXO} input range		0	-	V_{DD}	V
I_{VDD}	Supply Current		-	30	35	mA

AC Electrical Specifications ($V_{DD} = 3.3V$)^[4]

Parameter ^[4]	Name	Description	Min	Typ.	Max	Unit
DC	Output Duty Cycle	Duty Cycle is defined in Figure 4 , 50% of V_{DD}	45	50	55	%
ER_{OR}	Rising Edge Rate -1, -5	Output Clock Edge Rate, Measured from 20% to 80% of V_{DD} , $C_{LOAD} = 15$ pF See Figure 5 .	0.8	1.4	-	V/ns
ER_{OF}	Falling Edge Rate -1, -5	Output Clock Edge Rate, Measured from 80% to 20% of V_{DD} , $C_{LOAD} = 15$ pF See Figure 5 .	0.8	1.4	-	V/ns
t_g	Clock Jitter -1, -5	Peak-to-peak period jitter	-	140	-	ps
t_{10}	PLL Lock Time		-	-	3	ms

Notes

3. Rated for ten years.
4. Not 100% tested.

Figure 6. Test and Measurement Setup

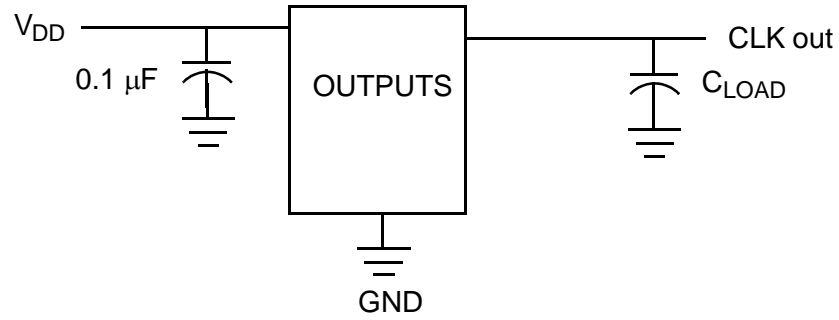

Ordering Information

Ordering Code	Package Type	Operating Range	Operating Voltage	Features
Pb-Free				
CY2410SXC-1 ^[5]	8-pin SOIC	Commercial	3.3V	Linear VCXO control curve
CY2410SXC-1T ^[5]	8-pin SOIC - Tape and Reel	Commercial	3.3V	Linear VCXO control curve
CY2410SXC-5 ^[5]	8-pin SOIC	Commercial	3.3V	Matches nonlinear MK3727A VCXO control curve
CY2410SXC-5T ^[5]	8-pin SOIC - Tape and Reel	Commercial	3.3V	Matches nonlinear MK3727A VCXO control curve
CY2410KSXC-5	8-pin SOIC	Commercial	3.3V	Matches nonlinear MK3727A VCXO control curve
CY2410KSXC-5T	8-pin SOIC - Tape and Reel	Commercial	3.3V	Matches nonlinear MK3727A VCXO control curve

Package Drawing and Dimensions

Figure 7. 8-Lead (150-Mil) SOIC

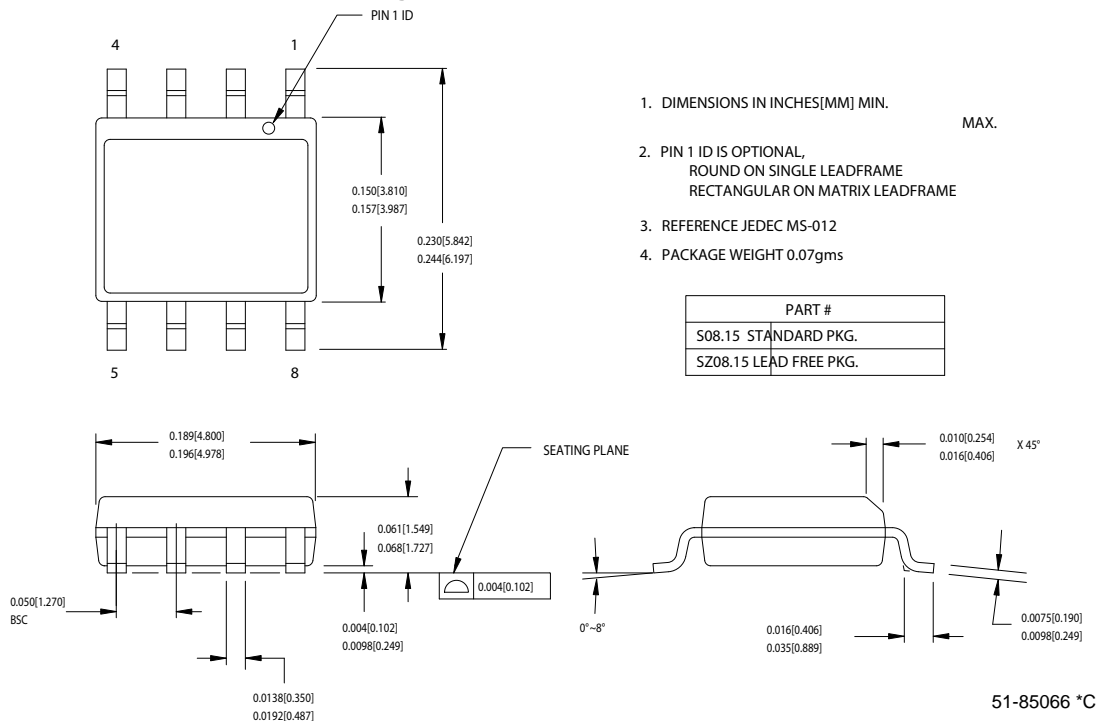

Note
5. Not recommended for new designs.

Document History Page

Document Title: CY2410 MPEG Clock Generator with VCXO Document Number: 38-07317				
REV.	ECN NO.	Submission Date	Orig. of Change	Description of Change
**	111553	02/12/02	CKN	New Data Sheet
*A	114937	09/24/02	CKN	Added -6 to data sheet, Advance Information to Final
*B	121418	12/06/02	CKN	Updated the Pullable Crystal Specifications table on page 2
*C	126905	06/17/03	RGL	Added -7 part to data sheet Added new parameter on the Pullable Crystal table Power up requirements added to the operating conditions
*D	131100	01/20/03	RGL	Added VCXO -7 pullability range in the DC Specs with min. value of ± 115 ppm
*E	2440886	See ECN	AESA	Updated template. Added Note "Not recommended for new designs." Added part number CY2410SXC-1, CY2410SXC-1T, CY2410SXC-5, CY2410SXC-5T, CY2410KSXC-5, and CY2410KSXC-5T in ordering information table. Removed all part numbers for non-Pb-free packages (part numbers beginning CY2410SC). Removed details specific to the -3, -4, -6 and -7 versions.

Sales, Solutions, and Legal Information

Worldwide Sales and Design Support

Cypress maintains a worldwide network of offices, solution centers, manufacturer's representatives, and distributors. To find the office closest to you, visit us at cypress.com/sales.

Products

PSoC	psoc.cypress.com
Clocks & Buffers	clocks.cypress.com
Wireless	wireless.cypress.com
Memories	memory.cypress.com
Image Sensors	image.cypress.com

PSoC Solutions

General	psoc.cypress.com/solutions
Low Power/Low Voltage	psoc.cypress.com/low-power
Precision Analog	psoc.cypress.com/precision-analog
LCD Drive	psoc.cypress.com/lcd-drive
CAN 2.0b	psoc.cypress.com/can
USB	psoc.cypress.com/usb

© Cypress Semiconductor Corporation, 2002-2008. The information contained herein is subject to change without notice. Cypress Semiconductor Corporation assumes no responsibility for the use of any circuitry other than circuitry embodied in a Cypress product. Nor does it convey or imply any license under patent or other rights. Cypress products are not warranted nor intended to be used for medical, life support, life saving, critical control or safety applications, unless pursuant to an express written agreement with Cypress. Furthermore, Cypress does not authorize its products for use as critical components in life-support systems where a malfunction or failure may reasonably be expected to result in significant injury to the user. The inclusion of Cypress products in life-support systems application implies that the manufacturer assumes all risk of such use and in doing so indemnifies Cypress against all charges.

Any Source Code (software and/or firmware) is owned by Cypress Semiconductor Corporation (Cypress) and is protected by and subject to worldwide patent protection (United States and foreign), United States copyright laws and international treaty provisions. Cypress hereby grants to licensee a personal, non-exclusive, non-transferable license to copy, use, modify, create derivative works of, and compile the Cypress Source Code and derivative works for the sole purpose of creating custom software and/or firmware in support of licensee product to be used only in conjunction with a Cypress integrated circuit as specified in the applicable agreement. Any reproduction, modification, translation, compilation, or representation of this Source Code except as specified above is prohibited without the express written permission of Cypress.

Disclaimer: CYPRESS MAKES NO WARRANTY OF ANY KIND, EXPRESS OR IMPLIED, WITH REGARD TO THIS MATERIAL, INCLUDING, BUT NOT LIMITED TO, THE IMPLIED WARRANTIES OF MERCHANTABILITY AND FITNESS FOR A PARTICULAR PURPOSE. Cypress reserves the right to make changes without further notice to the materials described herein. Cypress does not assume any liability arising out of the application or use of any product or circuit described herein. Cypress does not authorize its products for use as critical components in life-support systems where a malfunction or failure may reasonably be expected to result in significant injury to the user. The inclusion of Cypress' product in a life-support systems application implies that the manufacturer assumes all risk of such use and in doing so indemnifies Cypress against all charges.

Use may be limited by and subject to the applicable Cypress software license agreement.